



Hydraguide™ Series

Hydrostatic Steering Units

Catalog No. 1560-002/US

B

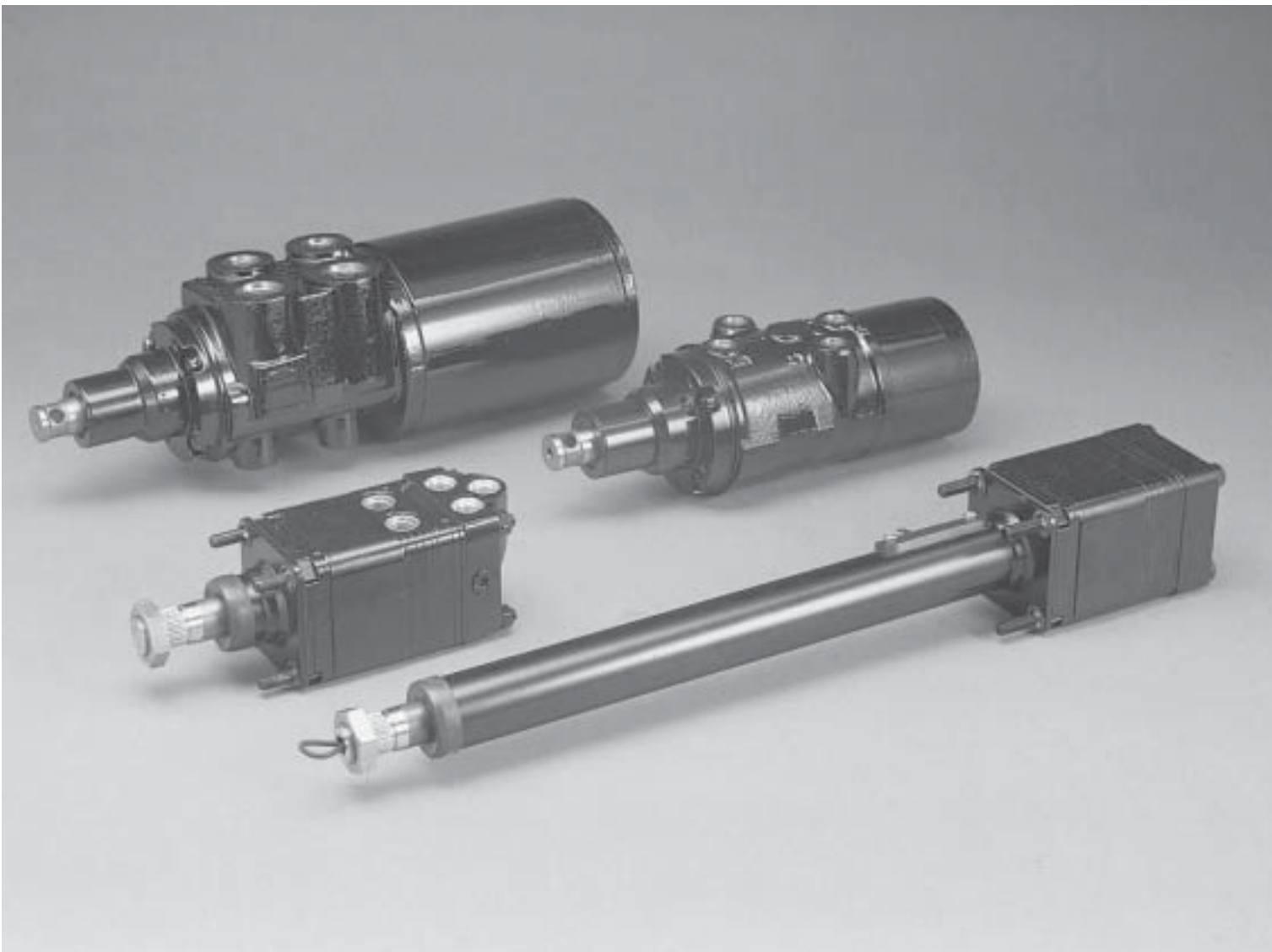

Selection Guide

HGF Series

Open Center
 Closed Center
 Power Beyond

Operating Parameters:

1800 PSI
 8 GPM
 3.3 to 9.9 cu. in.

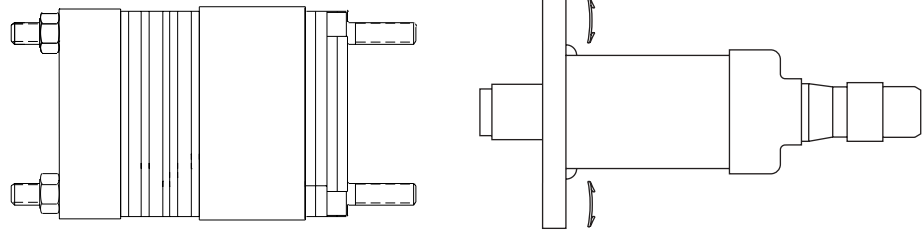

Typical Systems:

Turf, Material Handling, General Purpose,
 and Light Agricultural Vehicles.

HGA Series

Open Center
 Closed Center
 Power Beyond
 Load Sense

Operating Parameters:

2,500 PSI
 10 GPM
 5.94 to 23.74 cu. in.

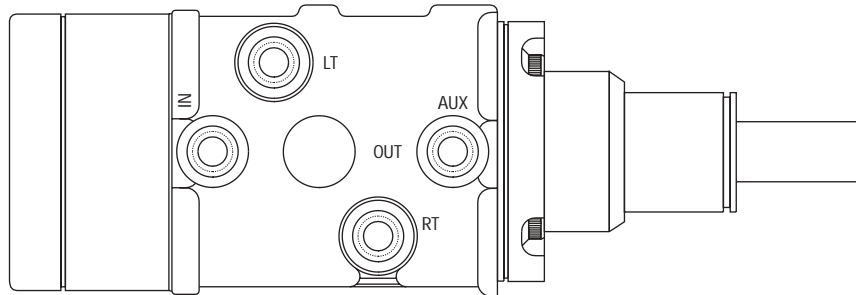

Typical Systems:

Medium Agricultural and Construction
 Vehicles.

HGB Series

Open Center
 Closed Center
 Power Beyond
 Load Sense

Operating Parameters:

2,500 PSI
 35 GPM
 30 to 120 cu. in.

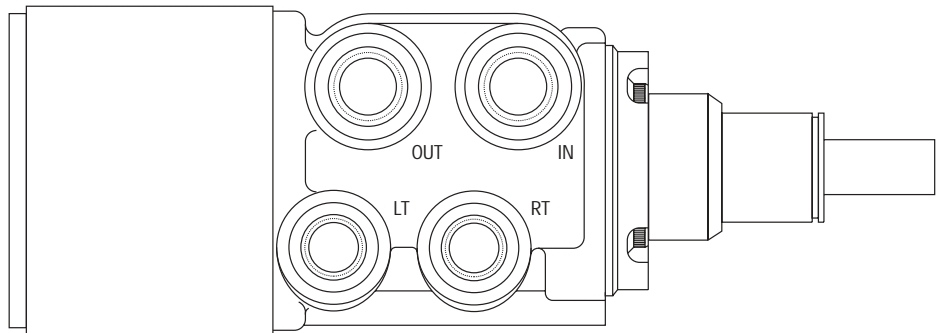

Typical Systems:

Large Agricultural, Mining, and
 Construction Vehicles.

Selection Guide

HGF

Hydraguide™ Series		08	10	12	16	20	24
Displacement (in ³ /rev) (cm ³ /rev)	English	3.30	4.13	4.95	6.60	8.25	9.9
	Metric	54.1	67.7	81.1	108.2	135.2	162.3
Operating Pressure (psi) (Bar)	Maximum	1800	1800	1800	1800	1800	1800
		125	125	125	125	125	125
Operating Temperature (°F) (°C)	Maximum	200	200	200	200	200	200
		93.3	93.3	93.3	93.3	93.3	93.3
Flow (gpm) (liters/min)	Continuous Rated	8	8	8	8	8	8
		30.3	30.3	30.3	30.3	30.3	30.3
	Recommended (120 rpm)	1.71	2.15	2.57	3.43	4.29	5.14
		6.47	8.14	9.73	12.98	16.24	19.45
Weight (lbs) (kg)		8.8	9.04	9.28	9.77	10.25	10.75
		3.99	4.10	4.21	4.43	4.65	4.88
“A” Dimensions* (in) (mm)		4.37	4.50	4.62	4.87	5.12	5.42
		111.0	114.2	117.3	123.6	130.0	137.5

HGA

Hydraguide™ Series		08	10	12	14	16	20	24	28	32
Displacement (in ³ /rev) (cm ³ /rev)	English	5.94	7.42	8.91	10.40	11.88	14.85	17.82	20.79	23.74
	Metric	97.4	121.6	146.0	170.5	194.7	243.4	292.1	340.8	389.1
Operating Pressure (psi) (Bar)	Maximum	2500	2500	2500	2500	2500	2500	2500	2500	2500
		175	175	175	175	175	175	175	175	175
Operating Temperature (°F) (°C)	Maximum	200	200	200	200	200	200	200	200	200
		93.3	93.3	93.3	93.3	93.3	93.3	93.3	93.3	93.3
Flow (gpm) (liters/min)	Continuous Rated	5	5	5	10	10	10	10	11	12
		18.9	18.9	18.9	37.9	37.9	37.9	37.9	41.6	45.4
	Recommended (120 rpm)	3.0	4.0	4.5	5.5	6.0	7.5	9.5	11.0	12.0
		11.4	15.1	17.0	20.8	22.7	28.4	36.0	41.7	45.4
Weight (lbs) (kg)		17.3	17.5	17.7	17.9	18.2	18.5	18.8	19.4	20.0
		7.85	7.94	8.01	8.12	8.26	8.39	8.53	8.80	9.07
“A” Dimensions* (in) (mm)		7.09	7.21	7.34	7.46	7.59	7.84	8.09	8.34	8.59
		180.1	183.1	186.4	189.5	192.8	199.1	205.5	211.8	218.2

HGB

Hydraguide™ Series		16	24	32	40	48	64
Displacement (in ³ /rev) (cm ³ /rev)	English	30	45	60	75	90	120
	Metric	491.7	737.6	983.4	1229.3	1475.1	1966.8
Operating Pressure (psi) (Bar)	Maximum	2500/***3000	2500/***3000	2500/***3000	2500/***3000	2500/***3000	2500/***3000
		175/210	175/210	175/210	175/210	175/210	175/210
Flow (gpm) (liters/min)	Continuous Rated	35	35	35	35	35	35
		132.5	132.5	132.5	132.5	132.5	132.5
	Recommended (120 rpm)	15.5	23.0	31.0	**35.0	**35.0	**35.0
		58.7	87.1	117.3	132.5	132.5	132.5
Weight (lbs) (kg)		37.0	40.0	43.0	46.0	49.0	52.0
		16.78	18.14	19.51	20.87	22.23	23.59
“A” Dimensions* (in) (mm)		9.77	10.27	10.77	11.27	11.77	12.77
		248.1	260.8	273.5	286.2	298.9	324.3

* Length from mounting face to end of Hydraguide endport only.

** Exceeds rated flow of unit.

*** Special housing for 3000 psi operation available.

1560-001_USA.P65.js,bl

Hydraguide™

Each Hydraguide unit consists of a directional control valve and metering section. The valve directs the pressurized oil supplied to and from the cylinder and the Hydraguide metering section. The metering section “meters” out the pressurized oil to the steering cylinder.

The Hydraguide works in conjunction with the vehicle’s hydraulic system, which consists of a steering cylinder(s), relief valve, reservoir, filter, fluid lines, and an engine driven pump to comprise a complete system. The systems must be tailored to the specific vehicle type and service for which it will be used. Parker offers engineering advice and assistance (and encourages use of our engineering assistance) when applying hydrostatic steering to any vehicle.

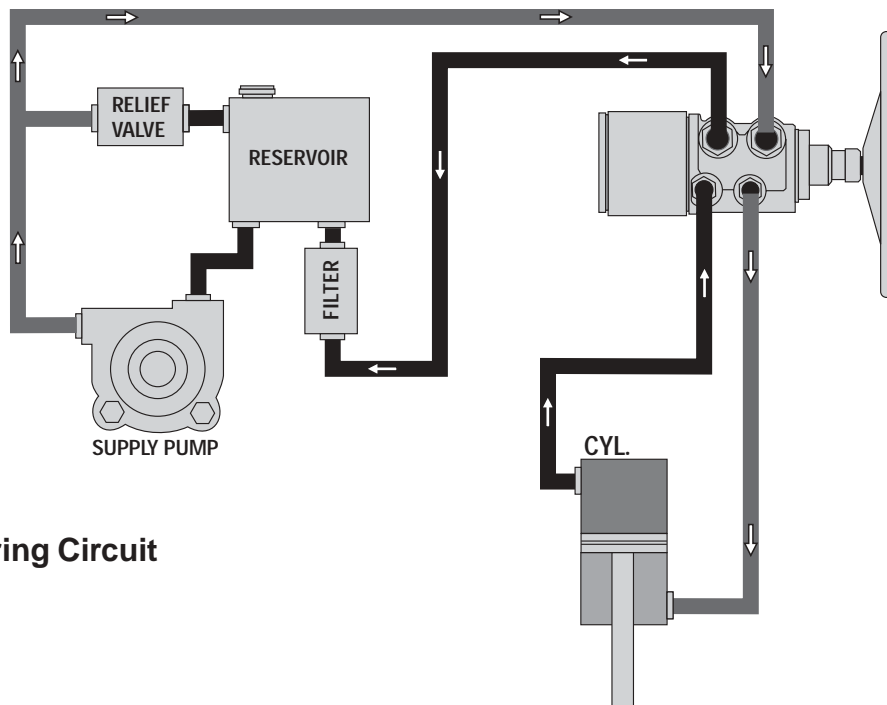

Typical Steering Circuit

Open Center, Nonreversing

The nonreversing unit keeps the steered wheels in the steered position when the operator releases the steering wheel. The cylinder ports are blocked in the neutral valve position. The operator must steer the wheels back to the straight ahead position.

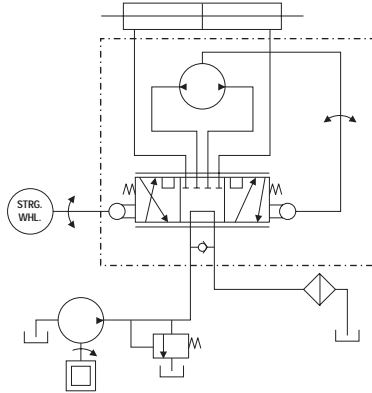

Open Center, Reversing

The reversing unit allows the steered wheels to return to the straight ahead position after the operator releases the steering wheel. This happens only if the steering geometry exerts a centering force on the steering cylinder. The cylinder ports are interconnected with the metering section so that the steering wheel follows the wheels back to center position.

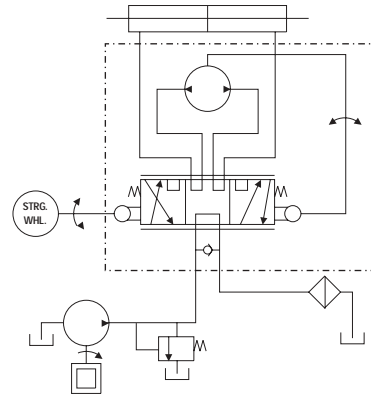

Open Center, Power Beyond (5-line)

The Hydraguide has an auxiliary fifth port as a Power Beyond feature to supply fluid to other functions downstream of the Hydraguide (Circuit #1). The Hydraguide automatically takes priority flow for steering, with the remainder available for auxiliary functions. When not steering, all flow is available to auxiliary functions. This system eliminates a flow divider or a separate steering circuit, thus saving energy and component cost.

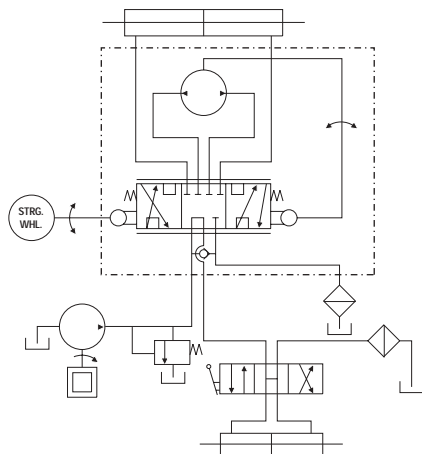

Open Center, Demand System

This system utilizes a fixed displacement pump, a priority demand valve to guarantee an adequate amount of flow to the steering unit, a closed center load sense steering unit, and open center auxiliary circuit valves.

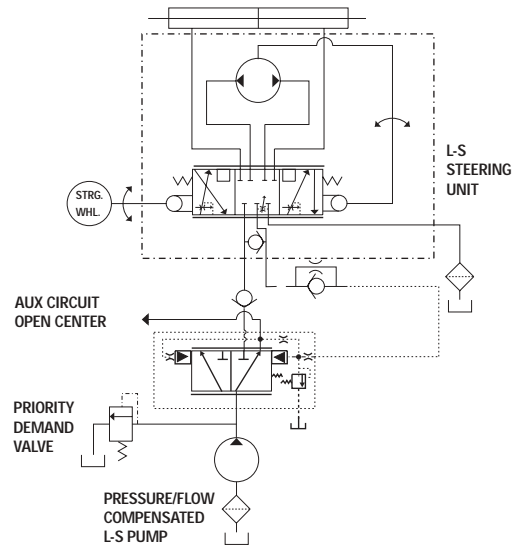

Closed Center System

Closed center systems utilize a variable displacement pump providing variable flow to the steering circuit. All ports of the Hydraguide™ are blocked when the vehicle is not being steered. The amount of flow through the steering circuit depends upon steering speed and displacement of the Hydraguide.

Closed Center, Nonreversing

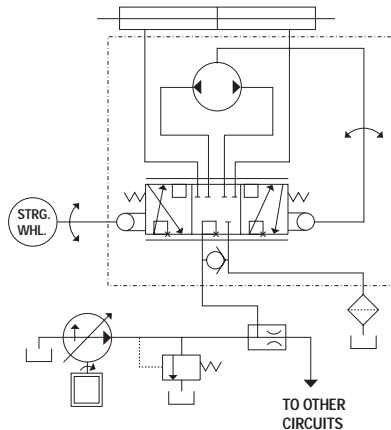

Closed Center System with Steering Priority Valve

This system utilizes a variable volume, pressure-compensated pump, a steering priority demand valve, a closed center load sense steering unit, and closed center auxiliary valves.

Closed Center Load Sense

This unit is a closed center design with a sense line for actuating the priority valve. Load sense is a flow and pressure modulation principle that provides a smooth steering transition. The function of the priority valve is to ensure a supply of power oil to the steering unit regardless of the downstream demand of the auxiliary valve.

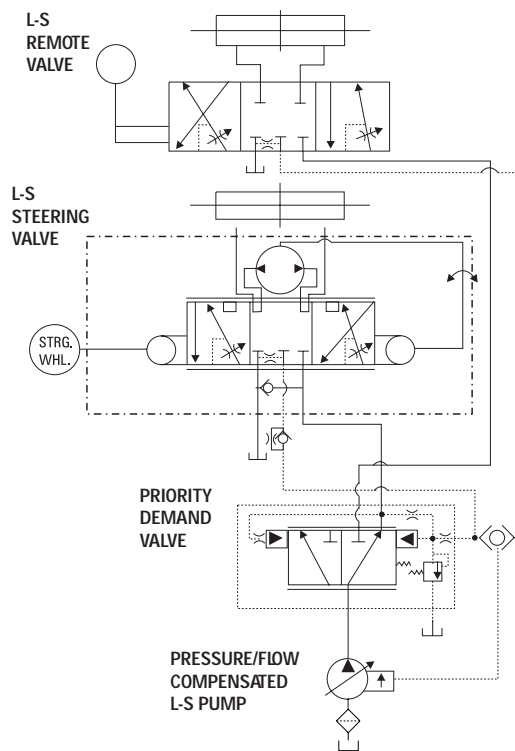
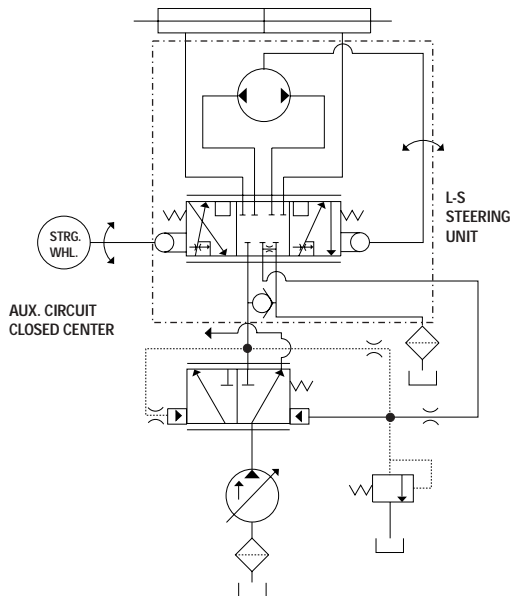

NOTE: If the auxiliary circuit requires a large demand from the pump, such that an inadequate amount of pump flow is available for steering, then a flow limiting control valve should be applied to the auxiliary circuit. This is needed to guarantee steering capability under all operating conditions.

Flow Chart

Use the following chart as a guide to design hydrostatic steering systems.

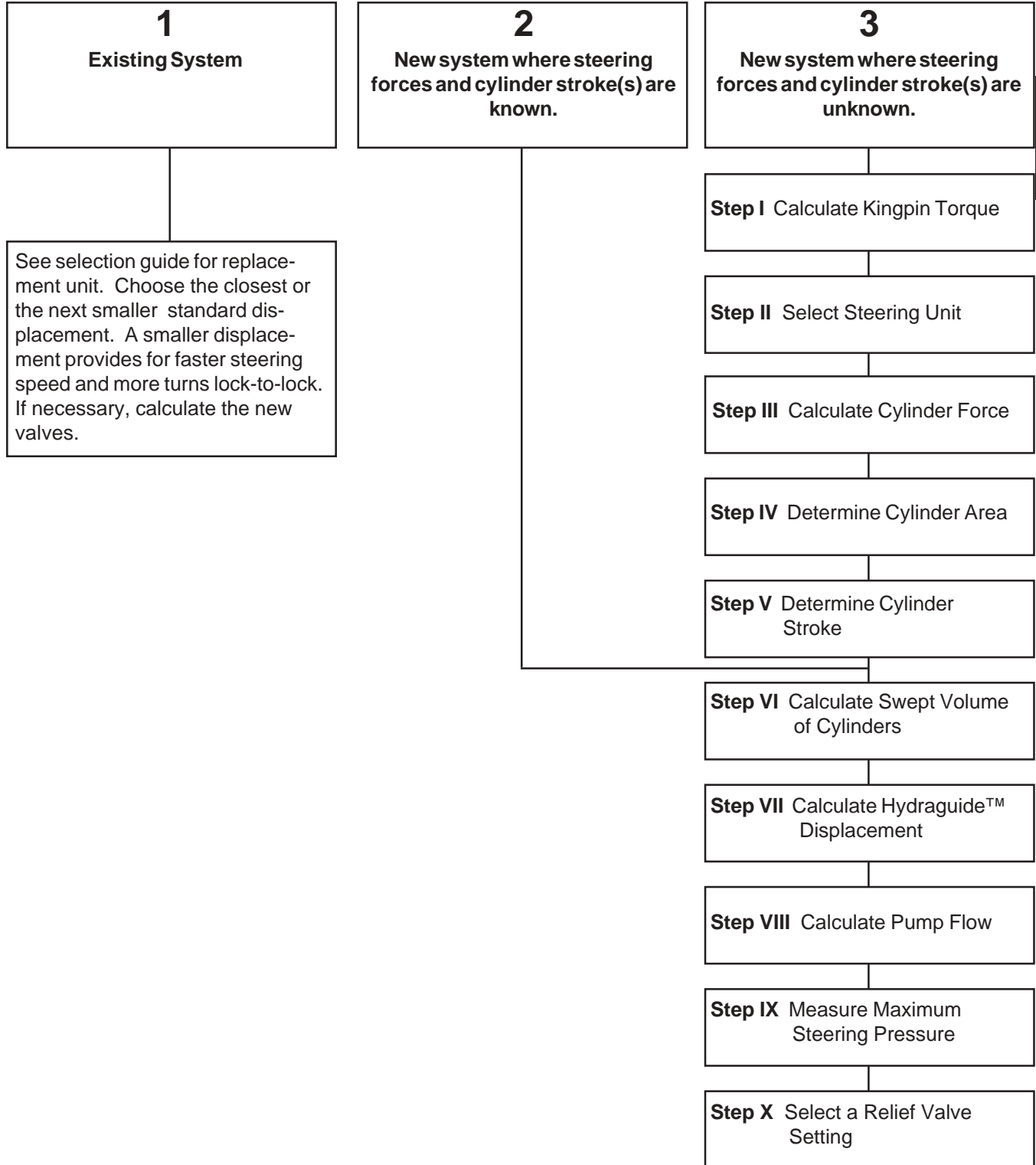

B

STEP I Calculate approximate Kingpin torque (KT)

1.1 Determine coefficient of friction:

Select the coefficient of friction (μ) from Chart 1 after calculating E/B. (Kingpin offset/nominal tire width). See Diagram 1.

Chart 1 (Rubber tires on dry concrete)

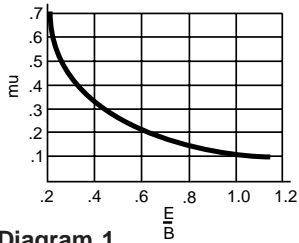
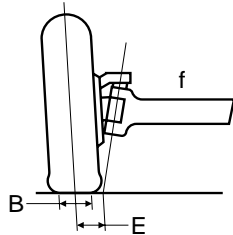

Diagram 1



1.2 Calculate Kingpin torque:

$$KT = W (\mu) \sqrt{\frac{B^2}{8} + E^2}$$

NOTE: If steered axle wheels are driven (powered), double KT.

Where:

- KT** = Kingpin torque in inch-pounds
- W** = Weight on steered axle in pounds (Use maximum overloaded weight anticipated.)
- μ** = Coefficient of friction
- B** = Nominal Tire width (inches)
- E** = Kingpin offset (inches) at the intersection with the ground

STEP II Select steering unit

For small garden tractor-type vehicles, select an HGF — for larger vehicles select HGA or HGB. The purpose of this is to establish what pressure to use in Step IV.

STEP III Calculate approximate cylinder force (CF)

$$CF = \frac{KT}{R}$$

Where:

- KT** = Kingpin torque (inch-pounds)
- R** = Minimum radius arm (inches) (see Diagram 2)

Diagram 2

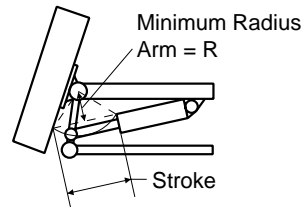

STEP IV Calculate cylinder area (CA)

$$CA = \frac{CF}{P}$$

Where:

- CF** = Cylinder force (pounds)
- P** = Pressure (psi) (This is the pressure rating of the steering unit chosen.)

Select the next *larger* common cylinder bore size available. If one cylinder is used, use the *rod end area* only and, if two are used, use the *rod end area plus the head end area* to select the cylinder (Step VI).

STEP V Determine cylinder stroke

Calculate using diagram 2 as a guide and the desired vehicle turning circle.

STEP VI Calculate swept volume (SV) of the cylinder(s)

6.1. One balanced cylinder, double acting



SV = (Bore area - rod area) x cylinder stroke

$$SV = \frac{\pi}{4} [B^2 - R^2] \times S$$

6.2. One unbalanced cylinder, double acting



a. Head side

$$SV = \frac{\pi \times B^2}{4} \times S$$

b. Rod side

Same as 6.1 above

6.3. Two unbalanced cylinders, double acting

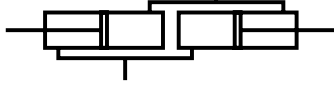

$$SV = \frac{\pi \times S}{4} (2B^2 - R^2)$$

Where:

- SV** = Swept volume (volume of oil to move cylinder full stroke) in cubic inches
- B** = Bore diameter (inches)
- R** = Rod diameter (inches)
- S** = Cylinder stroke (inches)

STEP VII Calculate Hydraguide™ displacement (HD)

$$HD = \frac{SV}{n}$$

Where:

- SV** = Swept volume in cubic inches from Step VI
- n** = Number of steering wheel turns lock-to-lock (from one end of cylinder stroke to the other). This ranges from 3 to 6 depending on the type of vehicle.

When one single rod cylinder is used, calculate n for each direction because it will be different. Select the next closest displacement. If desired, recalculate n as follows:

$$n = \frac{SV}{\text{Displacement of selected Hydraguide™}}$$

STEP VIII Calculate minimum pump flow (Q)

$$Q = \frac{HD \times SS \times 60}{231}$$

Where:

- Q** = Pump flow (gallons/minutes/revolutions)
- HD** = Hydraguide displacement (cubic inches)
- SS** = Steering speed (revolutions/seconds) (Ideal speed of steer = 120 rpms.)

Steering Speed

The minimum normally considered is 1 rev/sec (60 rpm). An example would be an articulated vehicle. This depends on the safety considerations for avoidance of obstacles under minimum *and* maximum flow conditions during all speed possibilities of the vehicle.

1.5 rev/sec (90 rpm) is common, and 2 rev/sec (120 rpm) is considered about the maximum input speed achievable by an average person.

If the steering wheel speed becomes greater than the pump flow, a dramatic increase in steering wheel effort is felt.

STEP IX Measure maximum steering pressure on prototype vehicle

Compare this pressure with the pressure rating of the Hydraguide. If it is higher, return to the last part of Step III and recalculate through Step IX again.

STEP X Select a relief valve setting

The cracking pressure of the relief valve, which is usually defined as the pressure when the relief valve starts to open and discharge flow to the return line, should be greater than the maximum pressure measured on the vehicle.

The full flow pressure of the relief valve, which is defined as the pressure when maximum flow is going over the relief valve, must not exceed the pressure rating on the steering unit.

NOTE:

Reversing units used with balanced area cylinders.

B

Hydraguide™ brand hydrostatic steering units were developed to meet the requirements of a broad range of off-highway applications. The HGF series is designed for light duty applications such as lawn and garden equipment, small agricultural equipment, small off-highway vehicles and material handling equipment.

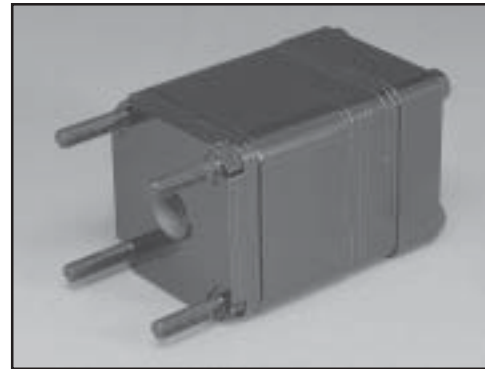
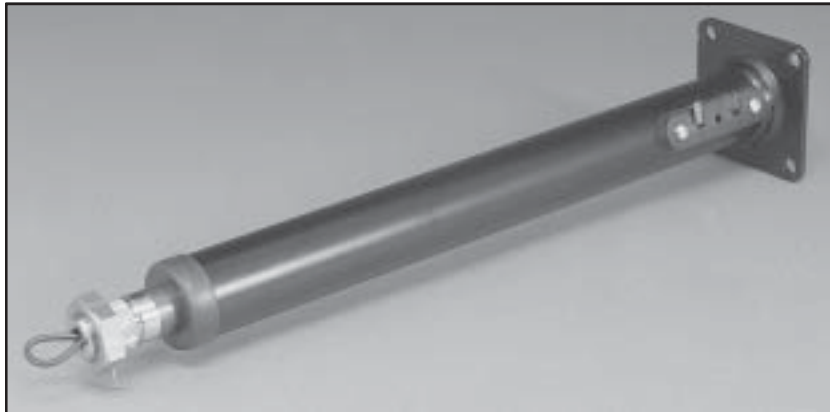

HGF Series Features

- **Compact Size**—The compact size of the HGF permits mounting in tight spaces to add overall machine design flexibility.
- **Full-Pressure Shaft Seal**—The Parker full pressure input shaft seal is able to withstand full system back pressure up to the pressure rating of the Hydraguide. This enables operation of auxiliary hydraulic functions downstream of steering.
- **Pressure Dams**—Pressure dams provide a barrier of pressurized system oil between metered oil and return. Pressure dam valving provides more precise steering due to the reduction of leakage oil from the metering element.
- **Needle Thrust Bearing**—The needle thrust bearing reduces input torque required to steer, resulting in lower steering efforts.
- **SAE #6 Female O-Ring Ports Standard.**
- **Integral Mounting Studs**—Integral mounting bolts minimize hardware cost and simplify installation, resulting in fewer service parts.
- **Manual Emergency Steering**—A ball check valve allows manual steering in emergencies when pump flow is interrupted. If the vehicle is large enough to require more than 100 ft.-lb. steering wheel torque in the manual mode, another means of emergency steering is recommended.
- **Integral Relief Available**—Five pressure settings from 500 to 1740 psi. Preset to protect steering unit from excessive system pressure.

HGF

Hydraguide™ Series		08	10	12	16	20	24
Displacement (in ³ /rev) (cm ³ /rev)	English	3.30	4.13	4.95	6.60	8.25	9.9
	<i>Metric</i>	54.1	67.7	81.1	108.2	135.2	162.3
Operating Pressure (psi) (Bar)	Maximum	1800	1800	1800	1800	1800	1800
		125	125	125	125	125	125
Operating Temperature (°F) (°C)	Maximum	200	200	200	200	200	200
		93.3	93.3	93.3	93.3	93.3	93.3
Flow (gpm) (liters/min)	Continuous Rated	8	8	8	8	8	8
		30.3	30.3	30.3	30.3	30.3	30.3
	Recommended ² (120 rpm)	1.71	2.15	2.57	3.43	4.29	5.14
		6.47	8.14	9.73	12.98	16.24	19.45
Weight (lbs) (kg)		8.8	9.04	9.28	9.77	10.25	10.75
		3.99	4.10	4.21	4.43	4.65	4.88
“A” Dimensions³ (in) (mm)		4.37	4.50	4.62	4.87	5.12	5.42
		111.0	114.2	117.3	123.6	130.0	137.5
“B” Dimensions (in) (mm)		5.3	5.4	5.6	5.8	6.1	6.4
		134.6	137.1	142.2	147.3	154.9	162.6

¹ English dimensions are control values; metric values are conversions.

² For two handwheel turns per second.

³ Length from mounting face to end of Hydraguide end.



Fluid/Filtration

Automatic transmission fluid (ATF) or contact your Parker Sales Engineer for other fluid recommendations.

Use 20-50 micrometer nominal filtration.

HGF Delta P -vs- Flow at 130° F (54.5° C) (113 SUS)

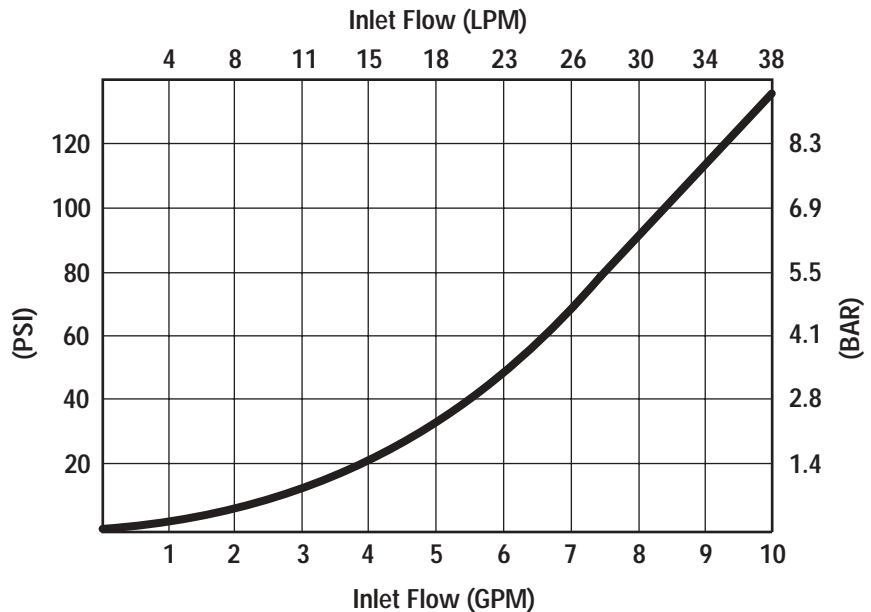

Dimensions

HGF Series

HGF Open Center (HGFXX2X0) HGF Power Beyond (HGFXX2X6)

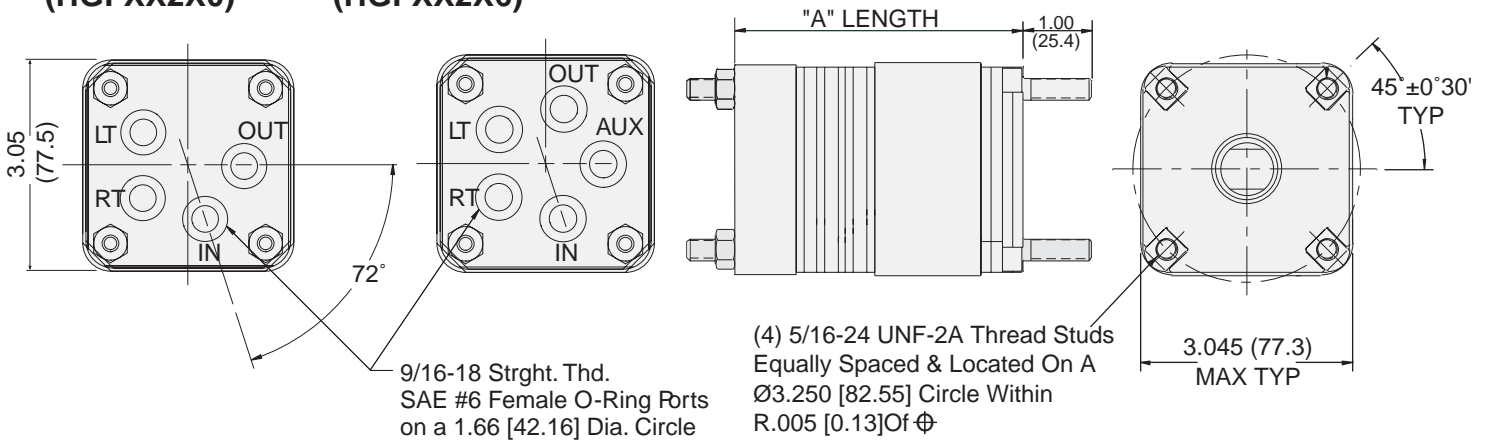

"A" Dimensions

Series	08	10	12	16	20	24
(in)	4.16	4.28	4.41	4.66	4.91	5.16
(mm)	105.7	108.7	112.0	118.4	124.7	131.1

HGF Open Center Sideport (HGFXX4X0)

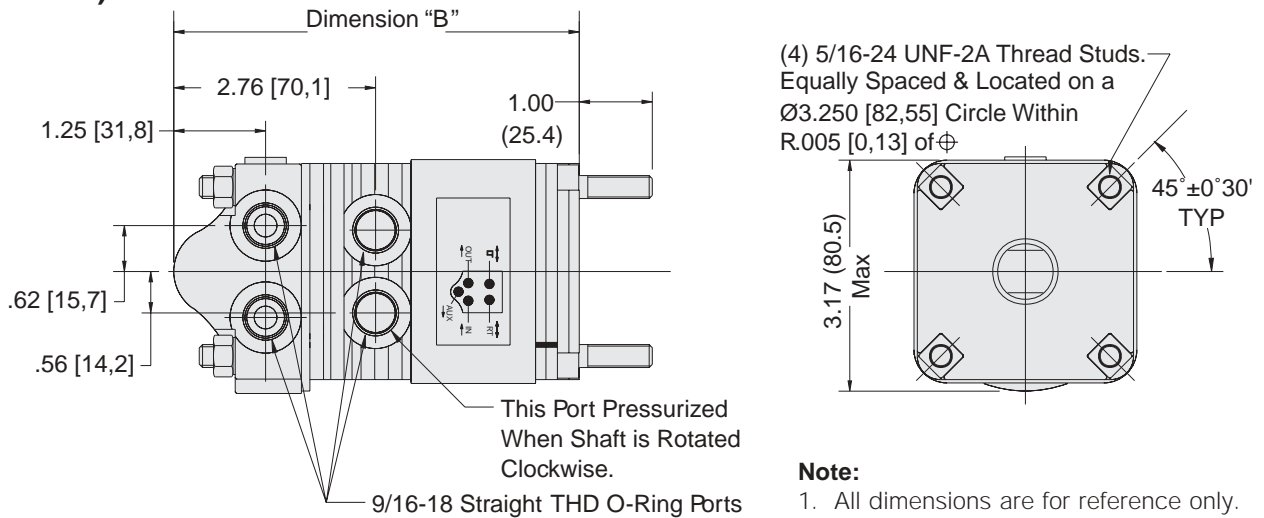

"B" Dimensions

Series	08	10	12	16	20	24
(in)	5.38	5.50	5.63	5.88	6.13	6.38
(mm)	136.6	139.7	143.0	149.3	155.7	162.1

Note:

1. All dimensions are for reference only.
2. Add .50 in (12.7 mm) for integral relief. Porting option 2 only)
3. Reversing units shall be used with balanced area cylinders.

Adapter Fittings

411085-A1

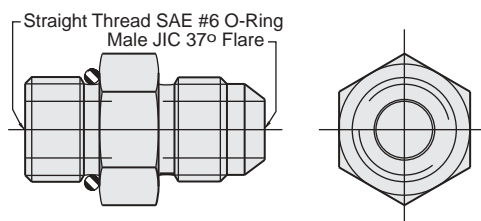

411090-A1

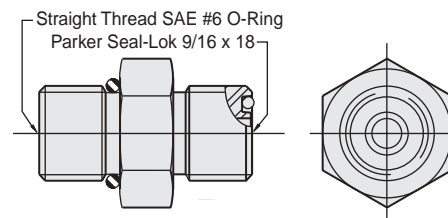

**HGF Power Beyond Sideport
(HGFXX4X6)**

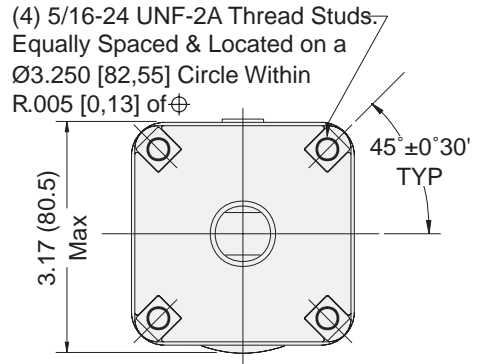
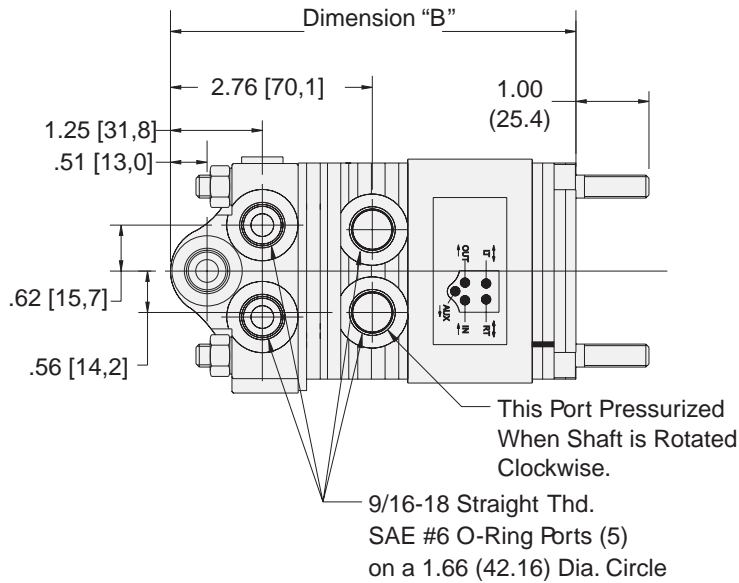

Note:

1. All dimensions are for reference only.
2. Add .50 in (12.7 mm) for integral relief. Porting option 2 only)
3. Reversing units shall be used with balanced area cylinders.

"B" Dimensions

Series	08	10	12	16	20	24
(in)	5.38	5.50	5.63	5.88	6.13	6.38
(mm)	136.6	139.7	143.0	149.3	155.7	162.1

**HGF Tilt Column
HTC01750**

- 5 positions
- 40° range of adjustment
- 3/4 x 40 serrations
- Can be mounted to end or side ported units



Standard Column

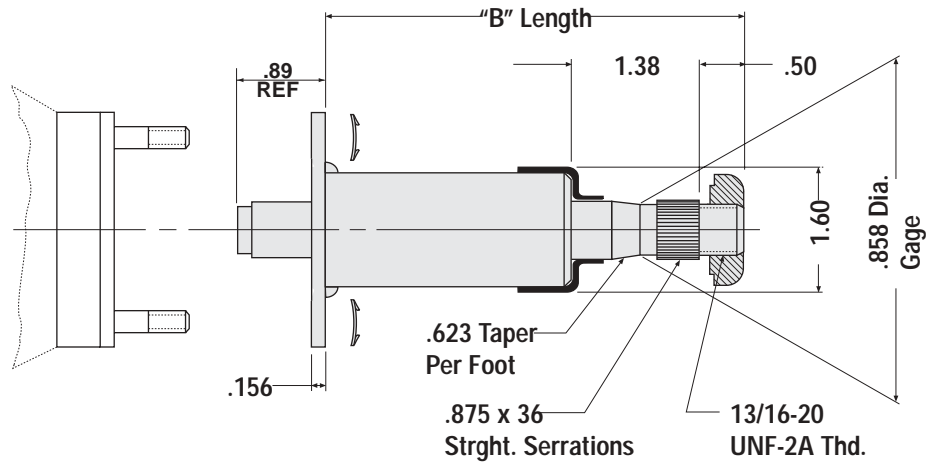

Hornwire Column
 (Single or Dual Contact)

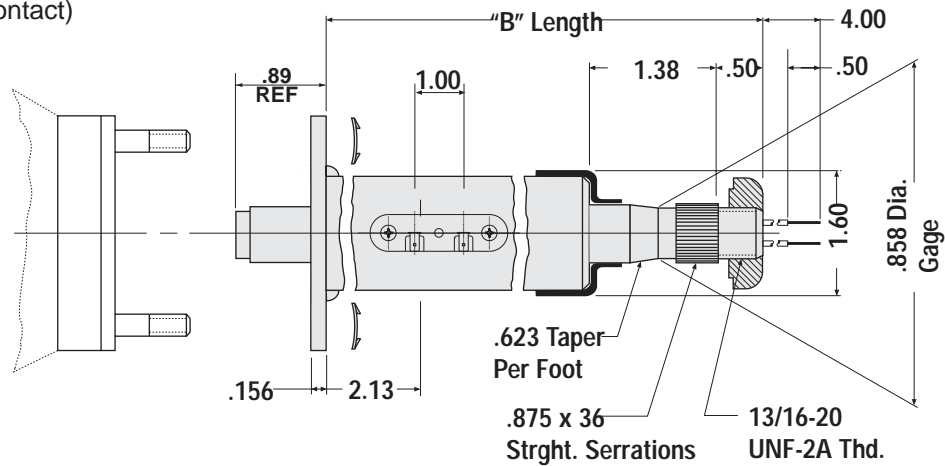

Notes:

1. All dimensions are for reference only.
2. Jacket tube diameter of all columns is 1.50 inches.
3. Column support is required for columns longer than 10 inches.
4. For "B" length see HGF Steering Column Selection Chart, page C16.

HGF

	Part Number	"B" Length - in (mm)	Specification
Standard	SKF00078-0400	4 (101.6)	7/8" x 36; no horn contact
	SKF00078-0600	6 (152.4)	7/8" x 36; no horn contact
	SKF00078-0800	8 (203.2)	7/8" x 36; no horn contact
	SKF00078-1200	12 (304.8)	7/8" x 36; no horn contact
	SKF00078-1600	16 (406.4)	7/8" x 36; no horn contact
	SKF00078-2200	22 (558.8)	7/8" x 36; no horn contact
	SKF00078-2400	24 (609.6)	7/8" x 36; no horn contact
	SKF00078-3200	32 (812.8)	7/8" x 36; no horn contact
	SKF00078-3450	34.5 (876.3)	7/8" x 36; no horn contact
Single Hornwire	SKF00178-0800	8 (203.2)	7/8" x 36; single horn contact
	SKF00178-1200	12 (304.8)	7/8" x 36; single horn contact
	SKF00178-1600	16 (406.4)	7/8" x 36; single horn contact
	SKF00178-2400	24 (609.6)	7/8" x 36; single horn contact
	SKF00178-3200	32 (812.8)	7/8" x 36; single horn contact
Dual Hornwire	SKF00278-0800	8 (203.2)	7/8" x 36; dual horn contact
	SKF00278-1200	12 (304.8)	7/8" x 36; dual horn contact
	SKF00278-1600	16 (406.4)	7/8" x 36; dual horn contact
	SKF00278-2400	24 (609.6)	7/8" x 36; dual horn contact
	SKF00278-3200	32 (812.8)	7/8" x 36; dual horn contact

HGF

	Part Number	"B" Length - in (mm)	Specification
Standard	SKF00034-0400	4 (101.6)	3/4" x 40; no horn contact
	SKF00034-0600	6 (152.4)	3/4" x 40; no horn contact
	SKF00034-0800	8 (203.2)	3/4" x 40; no horn contact
	SKF00034-1200	12 (304.8)	3/4" x 40; no horn contact
	SKF00034-1600	16 (406.4)	3/4" x 40; no horn contact
	SKF00034-2200	22 (558.8)	3/4" x 40; no horn contact
	SKF00034-2400	24 (609.6)	3/4" x 40; no horn contact
	SKF00034-3200	32 (812.8)	3/4" x 40; no horn contact
	SKF00034-3450	34.5 (876.3)	3/4" x 40; no horn contact
Single Hornwire	SKF00134-0800	8 (203.2)	3/4" x 40; single horn contact
	SKF00134-1200	12 (304.8)	3/4" x 40; single horn contact
	SKF00134-1600	16 (406.4)	3/4" x 40; single horn contact
	SKF00134-2400	24 (609.6)	3/4" x 40; single horn contact
	SKF00134-3200	32 (812.8)	3/4" x 40; single horn contact
Dual Hornwire	SKF00234-0800	8 (203.2)	3/4" x 40; dual horn contact
	SKF00234-1200	12 (304.8)	3/4" x 40; dual horn contact
	SKF00234-1600	16 (406.4)	3/4" x 40; dual horn contact
	SKF00234-2400	24 (609.6)	3/4" x 40; dual horn contact
	SKF00234-3200	32 (812.8)	3/4" x 40; dual horn contact

Notes:

1. Steering wheel horn button not included in column kits. Order part number 465611 separately.
2. Steering wheel nut included with column.
3. For column lengths or horn wires not shown above, contact your Parker Sales Engineer.



Model Number Explanation

HGF Series

Hydraguide™ Series

———— HGF X X X X X

**HGF
Displacement**

XX	in ³ /rev	cm ³ /rev
08	3.30	54.1
10	4.13	67.7
12	4.95	81.1
16	6.60	108.2
20	8.25	135.2
24	9.90	162.3

X	System	Type
0	Open Center	Nonreversing
1*	Open Center	Nonreversing (low noise)
2	Open Center	Reversing
6	Power Beyond	Nonreversing
3	Power Beyond	Reversing
4	Closed Center	Nonreversing
7	Closed Center	Reversing

* Only available with port option 2

X	Porting
2	Female #6 SAE O-Ring
4	Female #6 SAE O-Ring Side Port

X	Relief Option
2	No Relief
4	921 psi (64 Bar)
7	1200 psi (83 Bar)
6	1560 psi (108 Bar)
8	1740 psi (120 Bar)

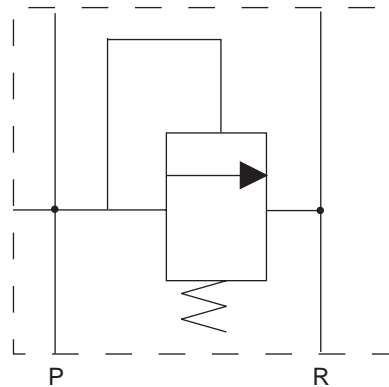

Example:

HGF08220 signifies HGF Hydraguide series unit with 3.30 in³/rev displacement, open center, nonreversing with female #6 SAE O-Ring ports.

The HGA and HGB series Hydraguide™ steering units are designed for applications such as large agricultural equipment including tractors, combines and other self-propelled, specialized harvesting equipment. In addition, these units are frequently specified for many medium-to-heavy-duty applications such as logging and construction equipment and marine and mining applications.

**B**

HGA/HGB Series Features

- **Full Pressure Shaft Seal**—The Parker full pressure input shaft seal is able to withstand full system back pressure up to the pressure rating of the Hydraguide. This enables operation of auxiliary hydraulic functions downstream of steering.
- **Linear Valve Spool**—The linear valve spool is less subject to stick and damage in the event of system contamination and allows generally better control.
- **Pressure Dams**—Pressure dams provide a barrier of pressurized system oil between metered oil and return. Pressure dam valving provides more precise steering due to the reduction of lost leakage oil from the metering element.
- **Vaned Rotor (HGA Only)**—The spring biased vanes in the rotor tips reduce leakage between pockets in the metering group. This provides more precise and positive steering.
- **Pressure Balanced Metering Group**—All Parker designs utilize a pressurized envelope around the metering package (rotor set—commutator) to reduce slippage leakage and provide more precise steering control.
- **Manual Emergency Steering**—A ball check valve allows manual steering in emergencies when pump flow is interrupted. If the vehicle is large enough to require more than 100 ft.-lb. steering wheel torque in the manual mode, another means of emergency steering is recommended.

HGA

Hydraguide™ Series		08	10	12	14	16	20	24	28	32
Displacement (in ³ /rev) (cm ³ /rev)	English¹	5.94	7.42	8.91	10.40	11.88	14.85	17.82	20.79	23.74
	Metric	97.4	121.6	146.0	170.5	194.7	243.4	292.1	340.7	389.1
Operating Pressure (psi) (Bar)	Maximum	2500	2500	2500	2500	2500	2500	2500	2500	2500
		175	175	175	175	175	175	175	175	175
Operating Temperature (°F) (°C)	Maximum	200	200	200	200	200	200	200	200	200
		93.3	93.3	93.3	93.3	93.3	93.3	93.3	93.3	93.3
Flow (gpm) (liters/min)	Continuous Rated	5	5	5	10	10	10	10	11	12
	Recommended ² (120 rpm)	3.0	4.0	4.5	5.5	6.0	7.5	9.5	11.0	12.0
Weight (lbs) (kg)		17.3	17.5	17.7	17.9	18.2	18.5	18.8	19.4	20.0
		7.85	7.94	8.01	8.12	8.26	8.39	8.53	8.80	9.07
"A" Dimensions³ (in) (mm)		7.09	7.21	7.34	7.46	7.59	7.84	8.09	8.34	8.59
		180.1	183.1	186.4	189.5	192.8	199.1	205.5	211.8	218.2

¹ English dimensions are control values; metric values are conversions.

² For two handwheel turns per second.

³ Length from mounting face to end of Hydraguide.

Fluid/Filtration

Automatic transmission fluid (ATF) or contact your Parker Sales Engineer for other fluid recommendations.

Use 20-50 micrometer nominal filtration.

HGA Delta P -vs- Flow at 130° F (54.5° C) (113 SUS)

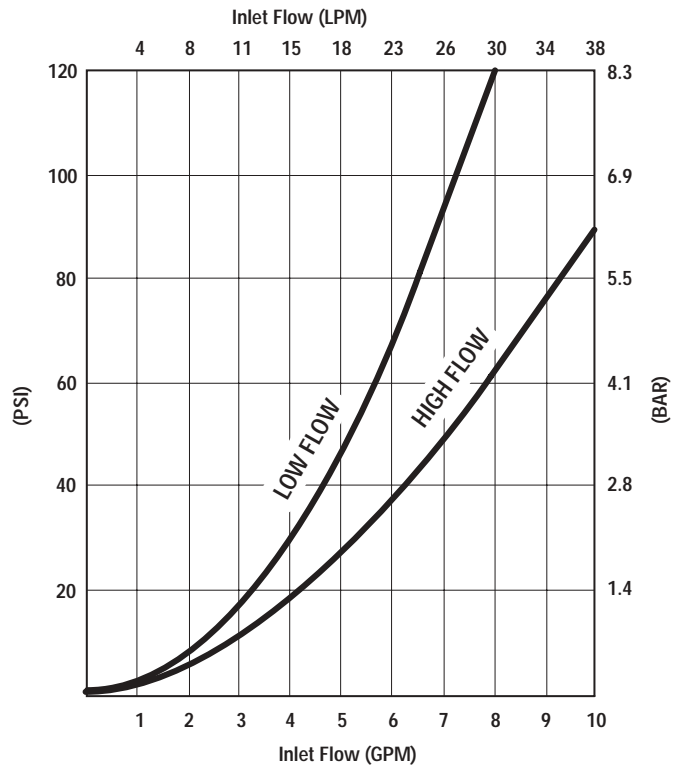

Note:

Option 1: Use low flow unit for 5 GPM or less.

Option 2: Use high flow unit for 5 to 10 GPM.

Open Center

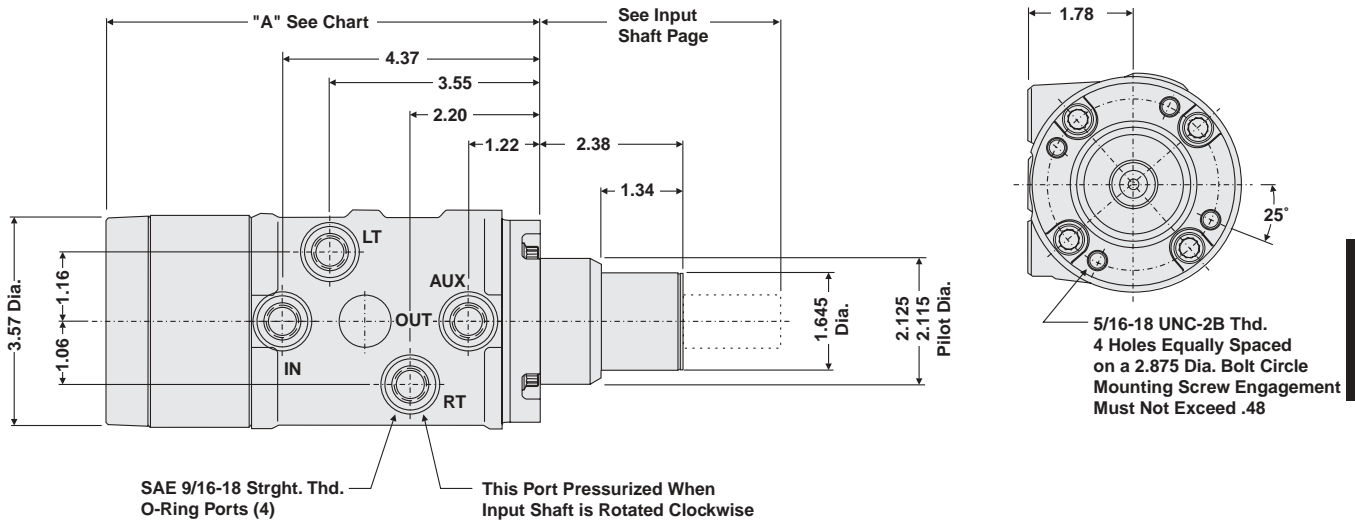

Load Sense

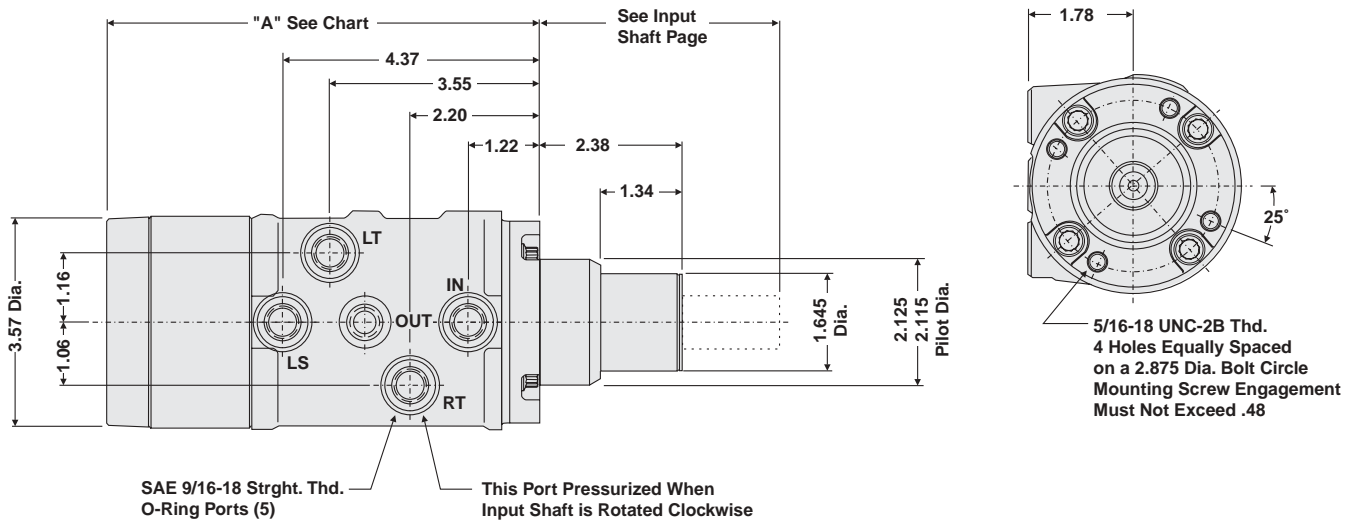

“A” Dimensions

Series	08	10	12	14	16	20	24	28	32
(in)	7.09	7.21	7.34	7.46	7.59	7.84	8.09	8.34	8.59
(mm)	180.1	183.1	186.4	189.5	192.8	199.1	205.5	211.8	218.2

Note:

1. All dimensions are for reference only.
2. Mounting screw engagement must not exceed .48.
3. Low flow units are used with 5 GPM or less flow from pump.
4. High flow units are used with more than 5 GPM flow from pump.
5. Reversing units should be used with balanced area cylinders.

Power Beyond

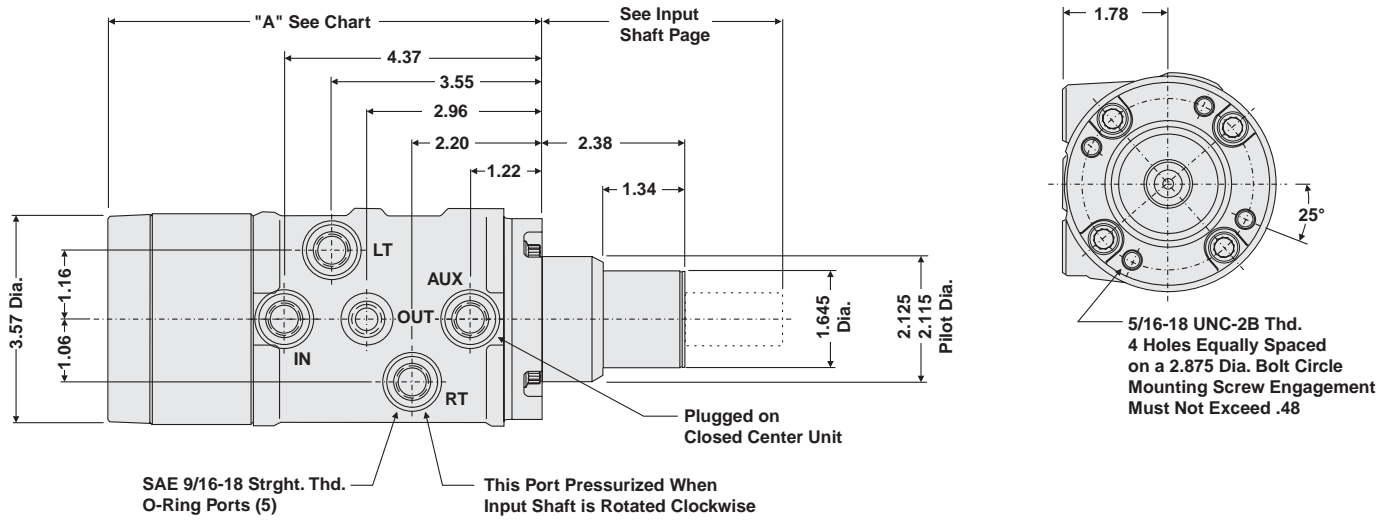

"A" Dimensions

Series	08	10	12	14	16	20	24	28	32
(in)	7.09	7.21	7.34	7.46	7.59	7.84	8.09	8.34	8.59
(mm)	180.1	183.1	186.4	189.5	192.8	199.1	205.5	211.8	218.2

Note:

1. All dimensions are for reference only.
2. Mounting screw engagement must not exceed .48.
3. Low flow units are used with 5 GPM or less flow from pump.
4. High flow units are used with more than 5 GPM flow from pump.

Column Mount

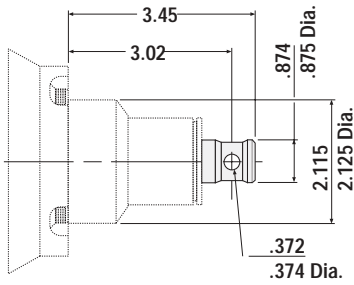

Direct Wheel Mount

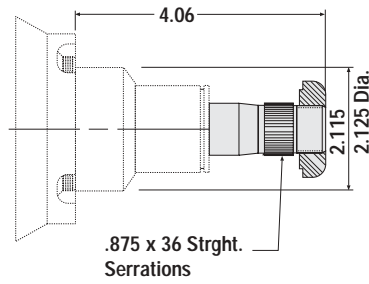

Standard Column

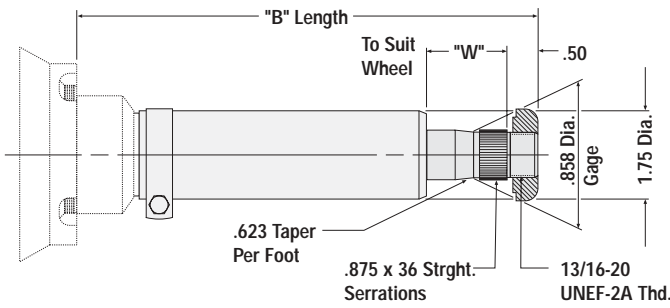

Hornwire Column

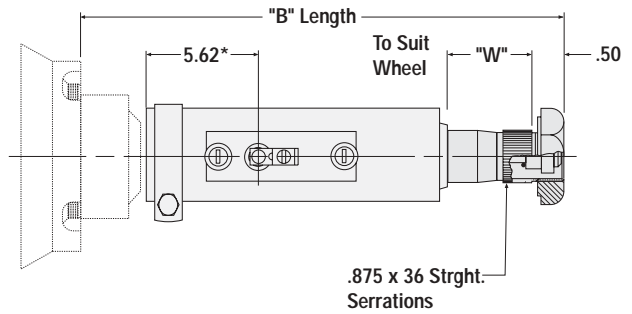

* Dimension is 4.62 for SK000014-1075 Column

Full Bolt Groove Shaft

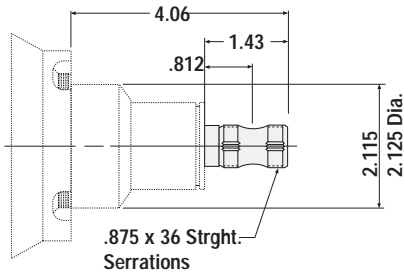

Notes:

1. All dimensions are for reference only.
2. Diameter of all columns is 1.75 inches.
3. Column support is required for columns longer than 14.25 inches.
4. Contact brush, screws, wheelnuts and spacer for horn button contact are assembled by customer.
5. For 'B' length see HGA Steering Column Selection Chart, page C29.

HGB

Hydraguide™ Series		16	24	32	40	48	64
Displacement (in ³ /rev) (cm ³ /rev)	English¹	30	45	60	75	90	120
	Metric	491.7	737.6	983.4	1229.3	1475.1	1966.8
Operating Pressure (psi) (Bar)	Maximum	2500/3000⁴	2500/3000⁴	2500/3000⁴	2500/3000⁴	2500/3000⁴	2500/3000⁴
		175/210	175/210	175/210	175/210	175/210	175/210
Operating Temperature (°F) (°C)	Maximum	200	200	200	200	200	200
		93.3	93.3	93.3	93.3	93.3	93.3
Flow (gpm) (liters/min)	Continuous	35	35	35	35	35	35
	Rated	132.5	132.5	132.5	132.5	132.5	132.5
	Recommended² (120 rpm)	15.5	23.0	31.0	**35.0	**35.0	**35.0
		58.7	87.1	117.3	132.5	132.5	132.5
Weight (lbs) (kg)		37.0	40.0	43.0	46.0	49.0	52.0
		16.78	18.14	19.51	20.87	22.23	23.59
“A” Dimensions³ (in) (mm)		9.77	10.27	10.77	11.27	11.77	12.77
		248.1	260.8	273.5	286.2	298.9	324.3

¹ English dimensions are control values; metric values are conversions.
² For two handwheel turns per second.
³ Length from mounting face to end of Hydraguide.
⁴ Special housing for 3000 psi operation available.

Fluid/Filtration

Automatic transmission fluid (ATF) or contact your Parker Sales Engineer for other fluid recommendations.

Use 20-50 micrometer nominal filtration.

**HGB Delta P -vs- Flow at
130° F (54.5° C) (113 SUS)**

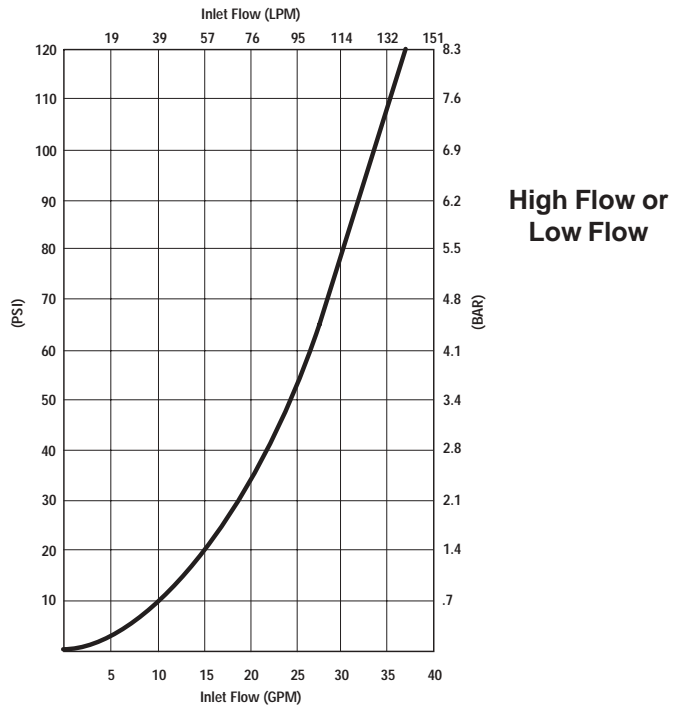

Note:

- Option 1: Use low flow unit for 5 GPM or less.
- Option 2: Use high flow unit for 5 to 10 GPM.

Open Center

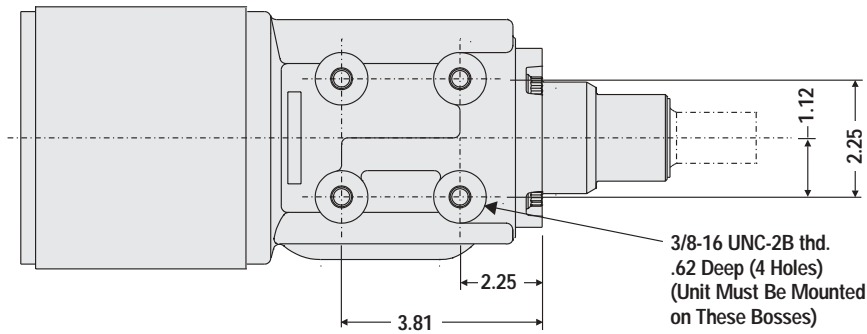
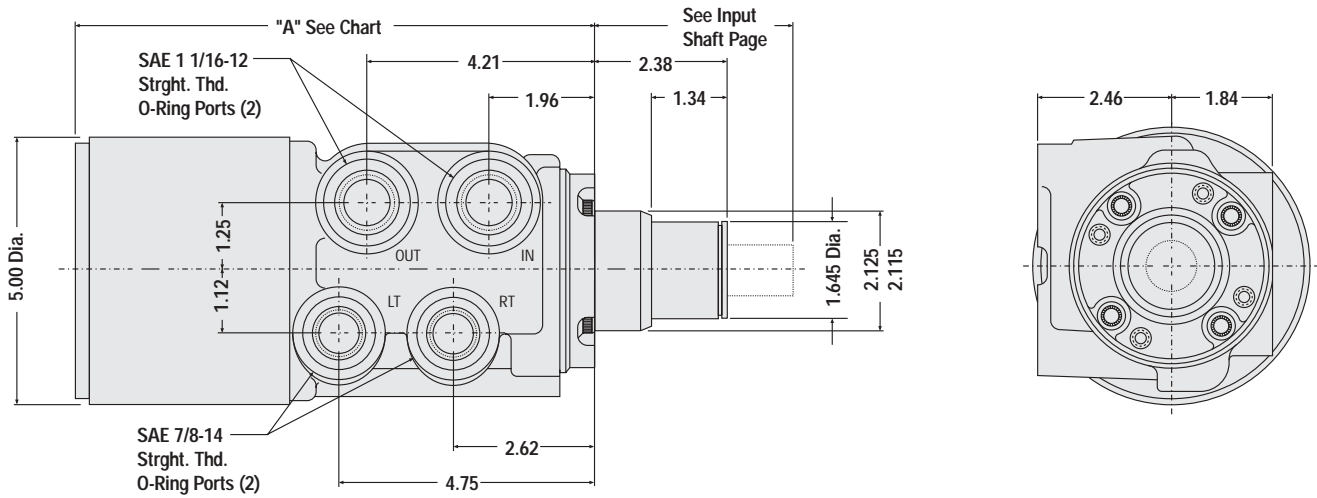

“A” Dimensions

Series	16	24	32	40	48	64
(in)	9.77	10.27	10.77	11.27	11.77	12.77
(mm)	248.1	260.8	273.5	286.2	298.9	324.3

Note:

1. All dimensions are for reference only.
2. Reversing units should be used with balanced area cylinders.

Power Beyond

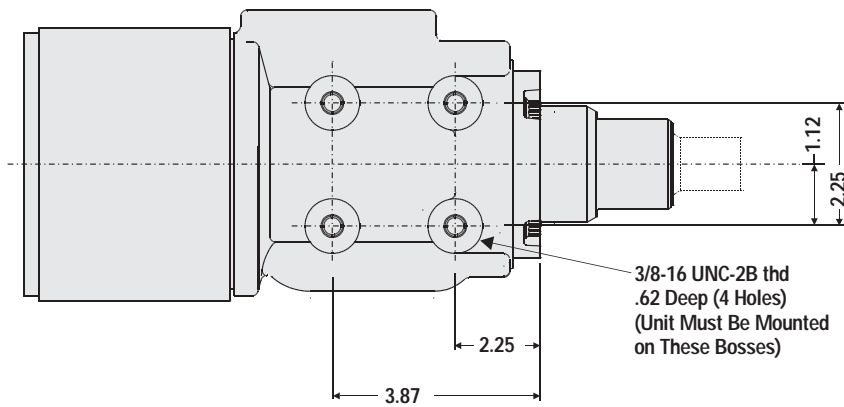
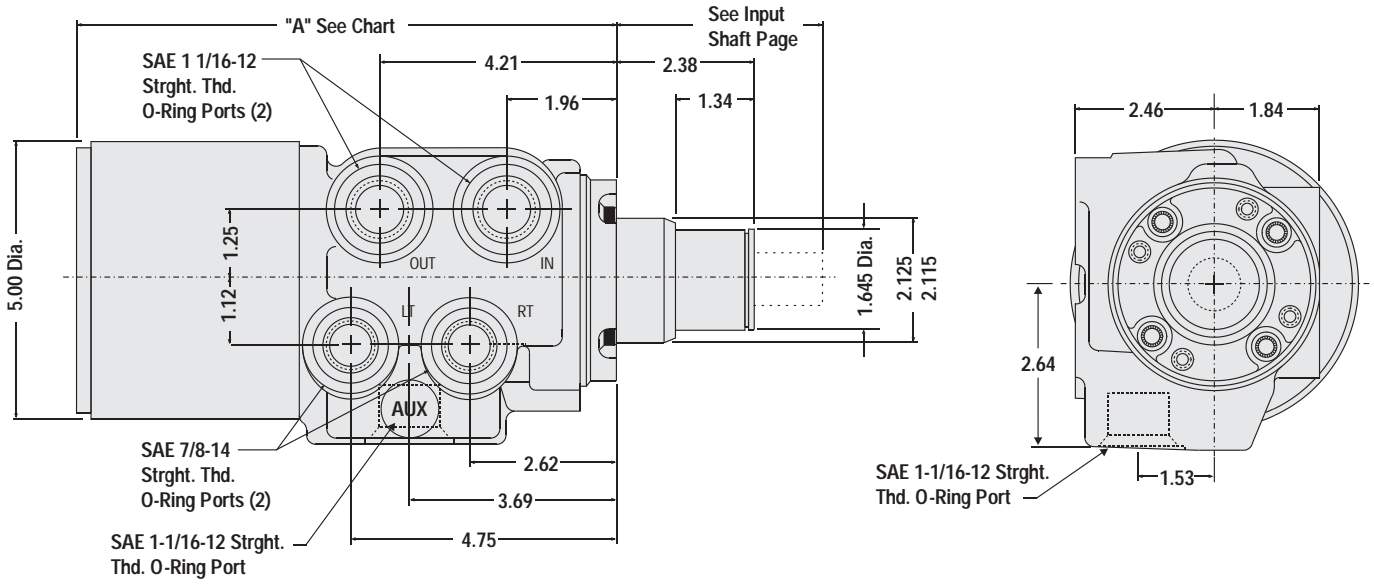

"A" Dimensions

Series	16	24	32	40	48	64
(in)	9.77	10.27	10.77	11.27	11.77	12.77
(mm)	248.1	260.8	273.5	286.2	298.9	324.3

Note:

1. All dimensions are for reference only.

Load Sense

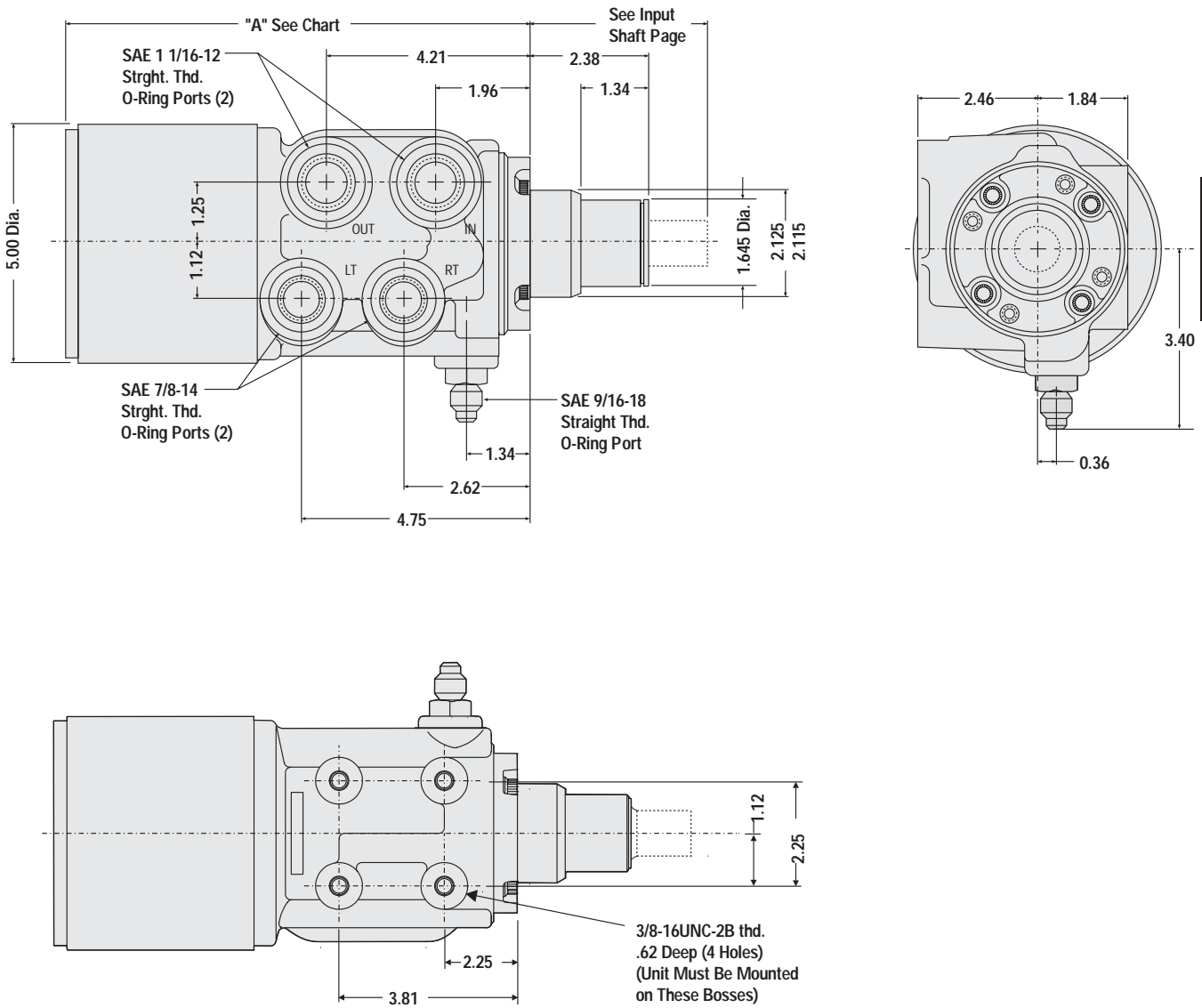

“A” Dimensions

Series	16	24	32	40	48	64
(in)	9.77	10.27	10.77	11.27	11.77	12.77
(mm)	248.1	260.8	273.5	286.2	298.9	324.3

Note:

1. All dimensions are for reference only.

Column Mount

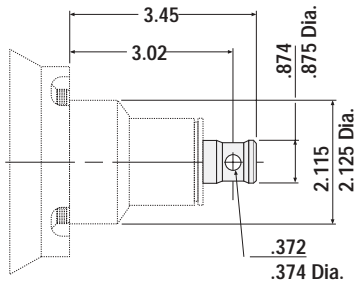

Direct Wheel Mount

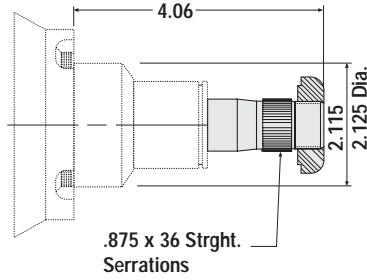

Standard Column

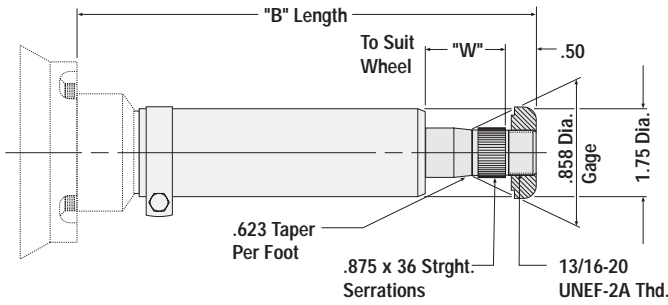

Hornwire Column

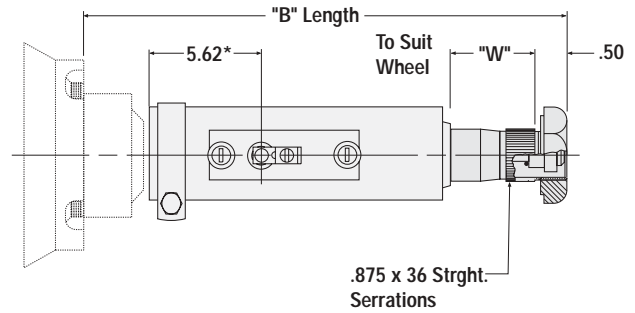

* Dimension is 4.62 for SK000014-1075 Column

Full Bolt Groove Shaft

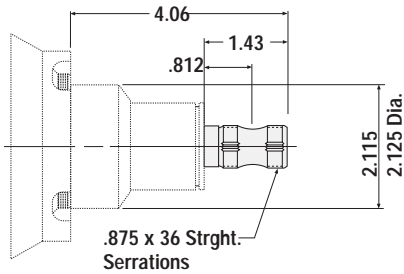

Notes:

1. All dimensions are for reference only.
2. Diameter of all columns is 1.75 inches.
3. Column support is required for columns longer than 14.25 inches.
4. Contact brush, screws, wheelnut, and spacer for horn button contact are packaged and assembled by customer.
5. For 'B' length see HGB Steering Column Selection Chart, page C29.

HGA/HGB

	Part Number	“B” Length in (mm)	Specification
Standard	SK000007-0875	8.75 (222.2)	7/8" x 36; no horn contact
	SK000007-1075	10.75 (273.0)	7/8" x 36; no horn contact
	SK000007-1275	12.75 (323.8)	7/8" x 36; no horn contact
	SK000008-1675	16.75 (425.4)	7/8" x 36; no horn contact
	SK000008-2375	23.75 (603.2)	7/8" x 36; no horn contact
	SK000008-2825	28.25 (717.5)	7/8" x 36; no horn contact
	SK000008-3125	31.25 (793.7)	7/8" x 36; no horn contact
	SK000008-3625	36.25 (920.7)	7/8" x 36; no horn contact
Hornwire	SK000014-1075	10.75 (323.8)	7/8" x 36; single horn contact
	SK000014-1275	12.75 (323.8)	7/8" x 36; single horn contact
	SK000014-1475	14.75 (374.6)	7/8" x 36; single horn contact
	SK000014-1675	16.75 (425.4)	7/8" x 36; single horn contact
	SK000014-2375	23.75 (603.2)	7/8" x 36; single horn contact
	SK000014-3175	31.75 (806.4)	7/8" x 36; single horn contact



Notes:

1. Horn button kit not included on steering column. Order part number 465611 separately.
2. Steering wheel nut included with column.
3. For column lengths not shown above, contact your Parker Account Manager.

Model Number Explanation

Hydraguide™ Series

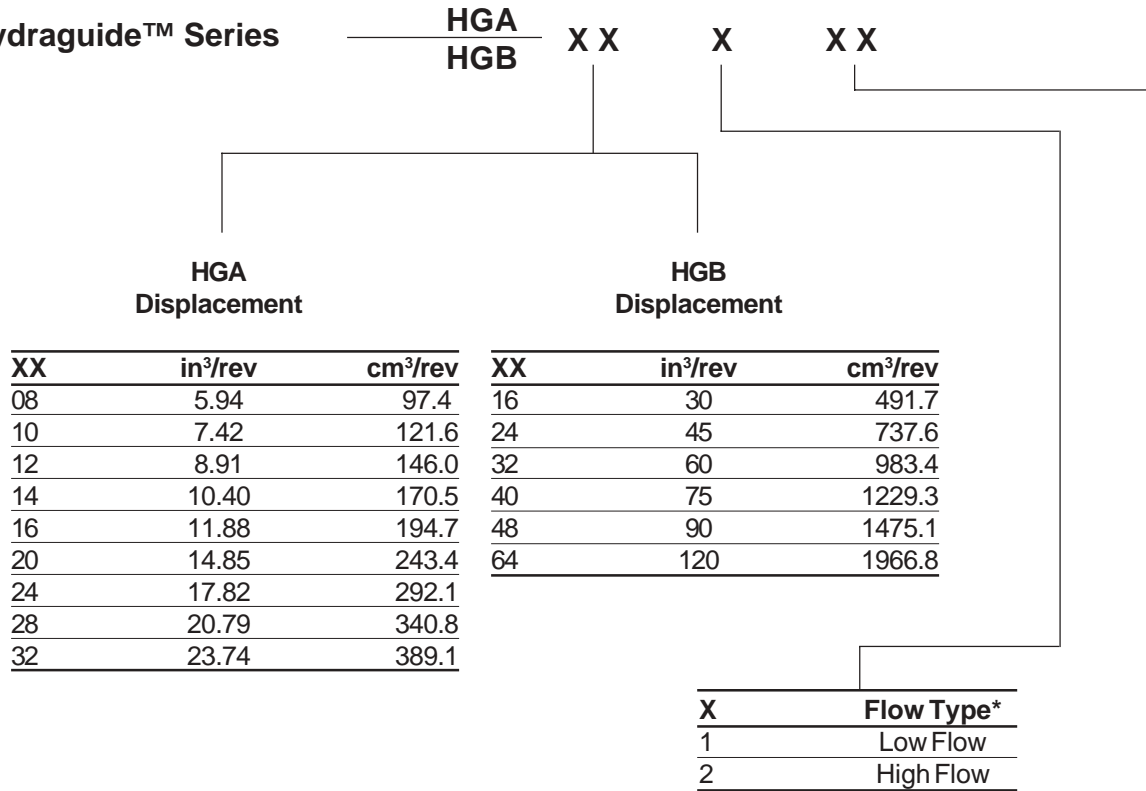

System	Type	XX	XX	Shaft	XX	XX
		Column Mount	Direct Wheel Mount		Full Bolt Groove	Integral Column**
Open	Nonreversing	20	21		30	40
Center	Reversing	22	23		32	42
Closed Center	Nonreversing	24	25		34	44
Power Beyond	Nonreversing	26	27		36	46
Load Sense/ Demand	Nonreversing	28	29		38	48

Example:

HGA10120 signifies HGA Hydraguide series unit with 7.42 in³/rev displacement, open center, nonreversing and column mount shaft.

*** Note:**

- HGA Low Flow 0-5 GPM
- HGA High Flow 5-10 GPM
- HGB Low Flow 0-25 GPM
- HGB High Flow 25-35 GPM

**** Note:** Integral column less than 10 inches consult factory.

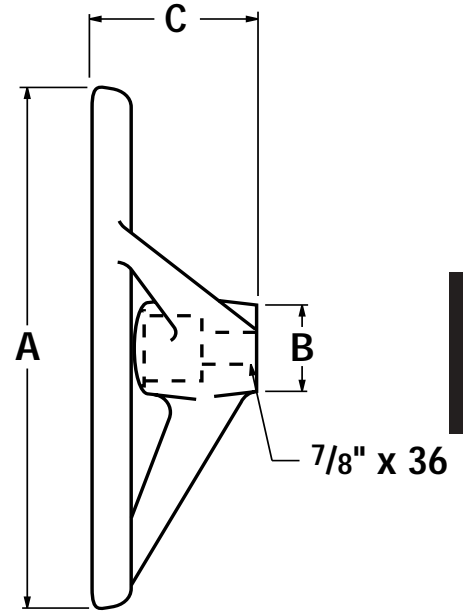
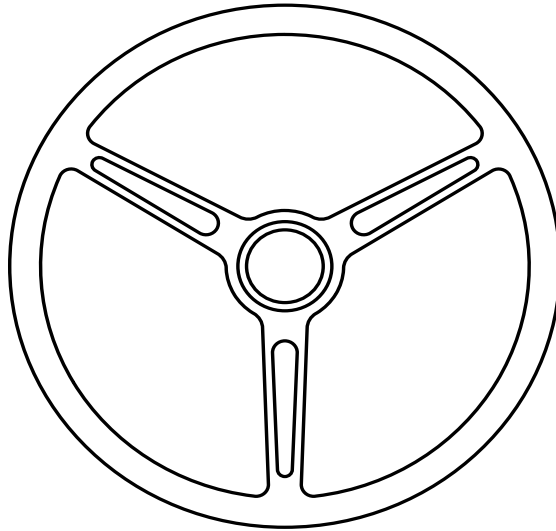

13-Inch Wheel 404264

- High impact plastic
- Flat black finish
- Will not accept horn button assembly

15-Inch Wheel 404265

- High impact plastic
- Flat black finish
- Will accept horn button assembly 465611

16-Inch Wheel 404266

- High impact plastic
- Gloss black finish
- Will accept horn button assembly 465611

Horn Button Kit 465611

Plain black horn button used with all horn wire column kits and 404265 (15-inch) wheel.

Specifications

A	Rim Diameter in. (mm)	B	Hub Diameter in. (mm)	C	Wheel Depth in. (mm)	Part #
	13.0 (330.2)		2.55 (64.7)		4.64 (118.1)	404264
	15.0 (381.0)		3.26 (82.8)		4.49 (114.1)	404265
	16.0 (406.4)		3.00 (76.2)		3.18 (80.8)	404266

Hydraguide™ System Data Sheet

Date _____

Salesperson _____

Phone _____ Fax. _____

1. Customer

Company _____

Address _____

City _____ State _____ Zip Code _____ Country _____

Customer Contact _____ Telephone _____ Fax _____

E-Mail Address _____

2. Vehicle

- Truck
 Tractor
 Lift Truck
 Earth Mover
 Other _____
 Articulated
 Ackerman
 Tricycle
 4-Wheel

3. Vehicle Specifications

3.1 Number of Steered Wheels _____ Front Wheel Steer Rear Wheel Steer Articulated

3.2 Gross Vehicle Weight and Maximum Weight on Steered Axle:

G.V.W. _____ Lbs. (Kg) G.F.E.W. _____ Lbs. (Kg)

4. Steering Unit

Operating Parameters

4.1 Number of Hand Wheel Turns Requested: _____ 4.1.1 Steering Effort @ Expectations _____ In Lb (Kg. cm.)

4.2 Speed of Steer (Seconds - Lock to Lock): Low Idle _____ Sec. High Idle _____ Sec.

4.3 Displacement of Steering Unit: _____ In.³/Rev. (cc/Rev.)

4.4 Reversing (Load Reactive) (Open Cylinder) Non-Reversing (Non-Load Reactive) (Closed Cylinder)

4.5 Power Beyond Open Center Closed Center Load Sense

4.6 Options Shock Valves (Crossovers) Anticavation Checks _____

Relief Valve in Steering Unit Yes No Setting _____ PSI/Kg/cm²

4.7 Hose Line Size _____

5. Steering Cylinder

5.1 Number Used _____ Balanced Yes No

5.2 Bore _____ In. (cm) 5.2.1 Stroke _____ In. (cm) 5.2.2 Rod Dia. _____ In (cm)

5.3 Amount of Stroke Used _____ In. (mm)

5.4 Cylinder Cross Port Relief Valves Yes No Pressure Settings _____ PSI (Kg/cm²)

5.5 Cylinder Line Size (I.D.) _____ Length _____

5.6 Expected Maximum Pressure _____

Hydraguide™ System Data Sheet

6. Pump

Model Number _____

Displacement: Fixed Variable

6.1 Flow Control Yes No Integral External

6.2 Pressure Relief Integral External Maximum Relief Setting _____ PSI (Kg/cm²)

6.3 Flow Divider Yes No

6.4 Pump Flow High Idle _____ GPM (L/min.) Low Idle _____ GPM (L/min)

6.5 Flow Available Maximum Steering Flow _____ GPM (L/min.) Minimum Steering Flow _____ GPM (L/min)

6.6 Full Engine Speed _____ RPM Idle Engine Speed _____ RPM



7. Reservoir

7.1 Capacity _____ Gal.

7.2 Location _____

Integral with Pump Yes No Separate _____ (Head Relative to Pump)

7.3 Filtration _____ Micron Normal Absolute

7.4 Expected Operating Temperature _____

8. Column and Steering Wheel Data

8.1 Steering Wheel Diameter _____ (In/cm)

8.2 Shaft Serration 3/4 x 40 7/8 x 36 Other _____

8.3 Upper Column Extension _____ Length Extended Yes No

8.4 Length Required _____ In/(cm)

Additional Information:

Multiple horizontal lines for additional information input.

